

Solutions for:

Cars

Trucks

Utility Vehicles

Special Vehicles

Diesel-Locomotives

Special Applications

Conveyor Technology

NORFI

Absaugtechnik

MORE THAN A CLEAN SOLUTION

BATTERY CHARGER CONVEYOR

**Perfect
integration...**



... into your production facilities



In car production lines, it often is necessary to charge the batteries of the vehicles. Otherwise, the cars are leaving the finish lines with only partly charged batteries and have to be taken to rectification areas where they then are connected to stationary chargers. Charging the batteries along the finish lines helps to avoid this additional work.

Especially for such applications, NORFI developed the battery charger conveyor system. This revolutionary solution allows for moving battery chargers of various brands synchronously with the vehicles without having a physical connection to them.

Thus, no forces are created that could have a negative impact on the vehicle or on the charger cable.

You see: NORFI solutions help to optimise your production.

Battery charger conveyor

1

Contact-free conveyor technology for moving battery chargers along vehicle production lines.

Contact-free conveyor technology

The NORFI battery charger conveyor system consists of individual carriage units which can travel along a transport rail. These rails are mounted above the conveyor belts.

Each carriage is built as an independent unit with its own drive and control box, allowing it to travel along the transport rail.

When in use, the carriages are positioned above the vehicles. They are not pulled by the vehicles, thanks to state-of-the-art sensor and monitoring technology. As the carriage is not pulled by the vehicle, there are no forces conducted via the charger cable. Thus, it is possible to close the bonnet during the charging process.



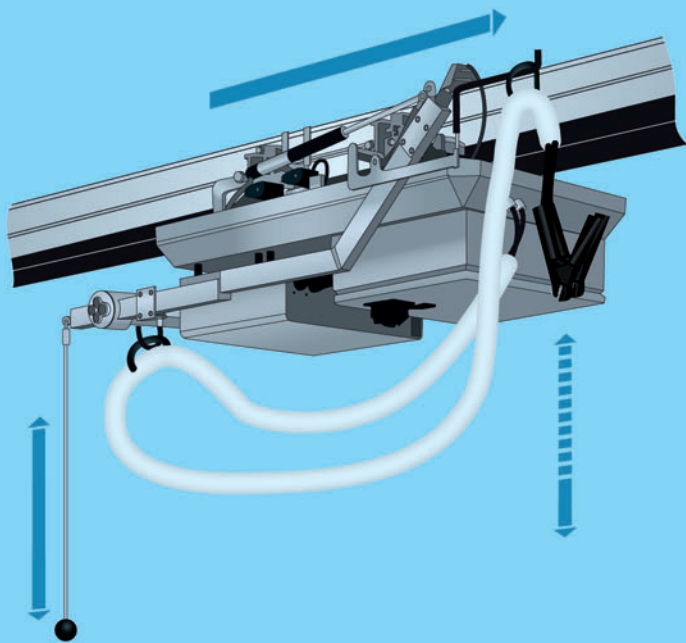

Automation technology

2

Each carriage unit includes its own drive unit and moves independently along the transport rail. For manual operation, a multifunctional push button panel can be provided.

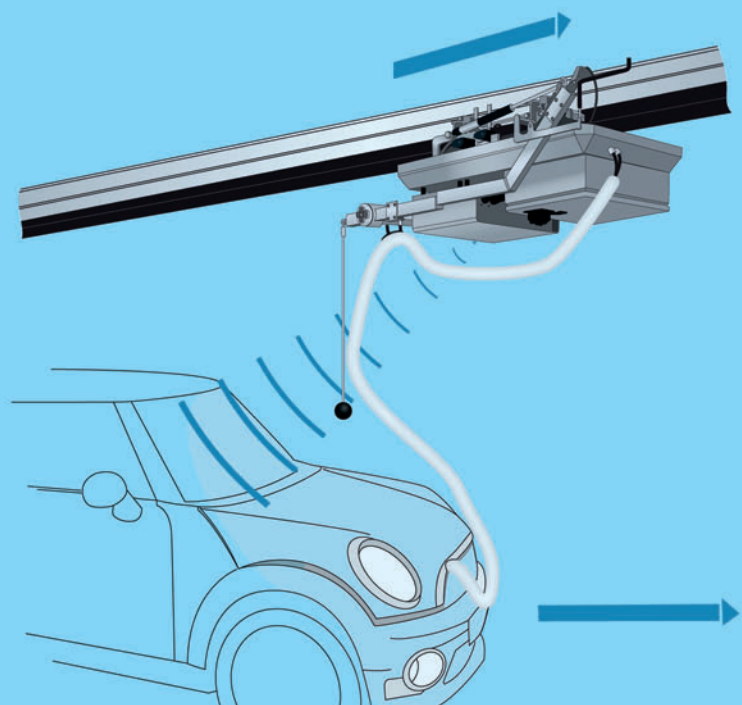

Control technology

3

Special ultrasonic sensors are constantly monitoring the distance between the charger and the vehicle. Their integrated controls allow the carriage units to move synchronously with the vehicle along the production line.

Automatic charging process

Step 1: Vehicle detection The carriage is waiting for a car at the beginning of the charger line. As soon as the vehicle is in the optimal position, a highly accurate sensor system activates the carriage which then drives into a well-defined start position.

Step 2: Charging process The operator pulls down the charger cable and connects it to the battery. The charging process is started. While the vehicle is moving along the production line, the battery charger is moved along with absolutely synchronous speed.

Step 3: Return At the end of the charger track, the operator has to disconnect the cable from the battery. The carriage units then drive back to the buffer area via a separate return track. Here, they are ready for the next use.

Manual operation

The multifunctional push button control allows for manual operation of the carriage unit: If required, the battery chargers can be moved to any position along the charger line by using the ergonomically positioned control device. It also offers the possibility to abort the charging process and to automatically send the carriage unit into the return track. At any time the operator has the possibility to switch from automatic to manual mode and back.

Flexibility

Our work is driven by your requirements. Thus, our battery charger conveyor systems can be equipped with practically all types of battery chargers, the charger lines are built to fit to your production lines, and your specific requirements - e. g. electrical specifications - are thoroughly observed by our specialists already in the planning stage.



NORFI Absaugtechnik GmbH

Kelterstraße 65
72669 Unterensingen
Germany

Tel.: +49 (0) 70 22 / 96 65-0

Fax: +49 (0) 70 22 / 6 52 80

Web: www.norfi.de

Email: info@norfi.de

PRESENTED BY:

Always an idea ahead

NORFI stands for over 30 years of competency in specialised extraction and conveyor technology. NORFI has a wide range of manufactured products and is staffed by experienced specialists.

NORFI provides well-designed technology - be it for advanced exhaust extraction or specialised conveyor systems. Tailor-made solutions are our standard!

Our standard begins where others end.

Cars

Trucks



Special Vehicles

Motorbikes



**NORFI's
Expertise**

Battery Charger
Conveyor

Special Applications,
Industry

